

TEACHER'S GUIDE

FOUNDATION PROGRAMME FOR LITERACY
NUMERACY AND SKILLS

INSTRUMENTAL MUSIC

GRADE 7

**TITLE : FESTIVALS AND
MUSICAL INSTRUMENTS OF MAURITIUS**

**MOE
MAHATMA GANDHI INSTITUTE
2026**

TABLE OF CONTENTS

Guide to Educators	01
Purpose of Activity	02
Learning Outcomes	03
Teaching Trajectories / Implementation Guidelines	
Part 1	04
Part 2	06
Part 3	07
Assessment Criteria	08
Rubric Assessment	09
Worksheet	10

GRADE 7

GUIDE TO EDUCATORS

TITLE : FESTIVALS AND MUSICAL INSTRUMENTS IN MAURITIUS



Competency

C 5 : Connecting

Element 3

Reflect on personal experiences through music

Performance Criteria

Level 2 : Shares simple connections between music and feelings

Purpose of Activity

The purpose of this activity is to help students understand the rich cultural diversity of Mauritius through its festivals and associated musical traditions. Learners explore how music plays an important role in religious, cultural, and community celebrations.

Through discussion, group research, and presentation, students develop appreciation for multiculturalism, respect for different traditions, and awareness of Mauritian cultural heritage. The activity encourages active participation, collaboration, and experiential learning through rhythm and performance.

Learning Outcomes

By the end of the lesson, students should be able to:

- Identify simple musical instruments associated with local festivals.
- Recognise the cultural origins of different festivals and their musical traditions.
- Appreciate the value of different cultural practices through active participation and observation.
- Share what they have learned about instruments and festivals in a simple presentation or group activity.

Resources & Materials

- Images of musical instruments being used in festivals.
- Short video / audio clips.
- Musical instruments (as per availability).
- Student's Workbook.

Teaching Trajectories / Implementation Guidelines

Part 1

Introduction

Festivals play an important role in the social and cultural life of Mauritius. As a multicultural country, Mauritius is home to diverse communities, each celebrating its own religious and cultural traditions such as Cavadee, Divali, Eid, Christmas, Chinese Spring Festival, and Maha Shivaratri. These festivals promote unity in diversity, bringing people together through shared values of respect, harmony, and celebration. They also preserve cultural heritage by passing traditions, music, food, rituals, and customs from one generation to another. Through festivals, Mauritians strengthen community bonds, express their identity, and celebrate the rich cultural mosaic of the nation.

Welcome students and introduce the theme “Festivals and Musical Instruments in Mauritius.”

Brief discussion:

- What festivals are celebrated in Mauritius?
- How is music used during festivals?
- Explain the importance of music in the Mauritian cultural life.

Instructions:

- Briefly explain the importance of music and festivals in the Mauritian culture.
- Show pictures or videos of key musical instruments used in Mauritian festivals.
- Mention the major festivals celebrated (e.g. Cavadee, Holi, Divali, Chinese Spring Festival, Eid...etc)

Part 2

(GROUP ACTIVITY) - Cultural Fair Simulation

Instructions:

- Divide the students into small groups.
- Assign each group one festival celebrated in Mauritius.
- Each group should:
 - Prepare a mini presentation about their festival
 - Identify musical instruments or music related to the celebration

(Examples of some musical instruments)

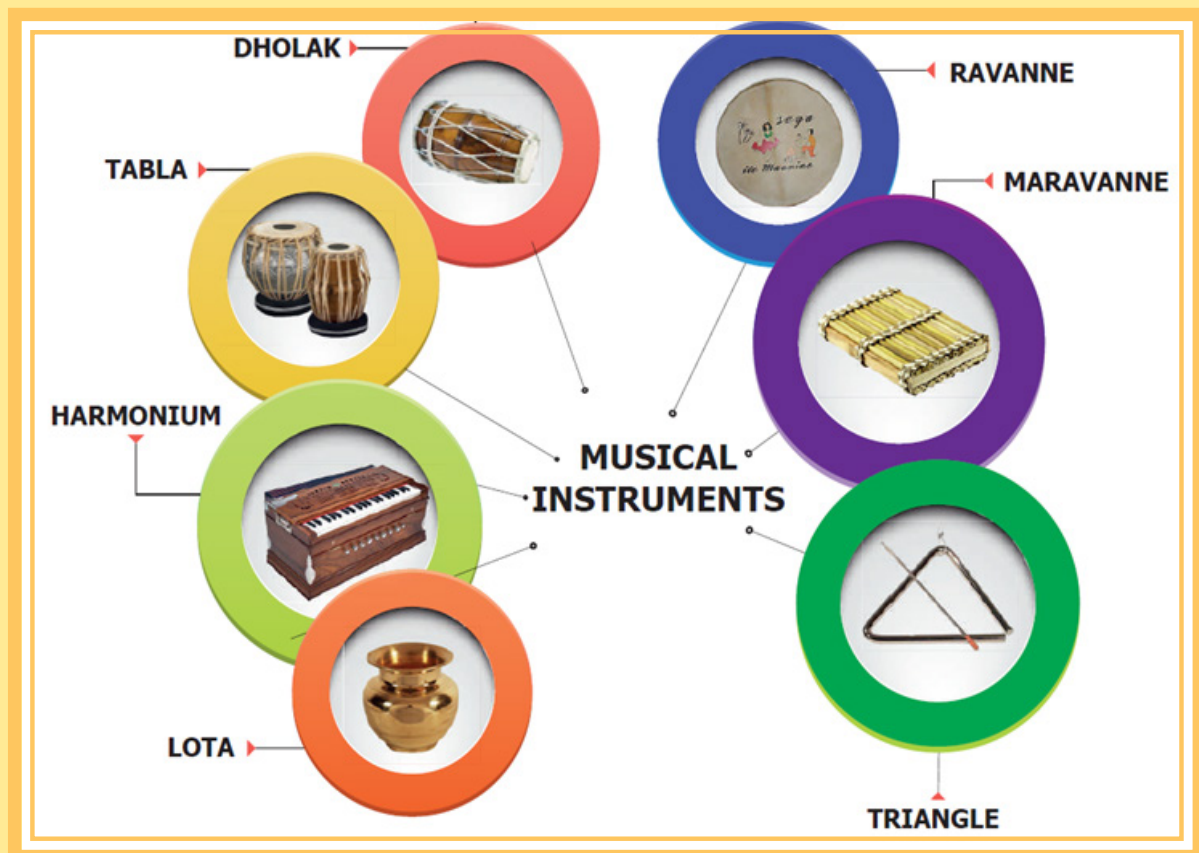

- Include a traditional song or rhythm if possible (can play from phone / speakers or perform)
- Provide basic percussion instruments (or improvised ones like shakers) for students to try playing simple rhythmic patterns.



Part 3

Sharing & Reflection

Instructions:

- Each group presents their festival and musical findings.
- Encourage other students to ask questions or share experiences.
- Wrap up with a fun group performance using simple Sega rhythms (teacher leads with a Ravanne or audio track).



Assessment Criteria

Students will be assessed on:

1. Understanding of Music Concepts

- Ability to identify festivals and their origins.
- Ability to associate appropriate instruments with each festival.

2. Participation & Collaboration

- Active engagement in group research and discussion.
- Contribution to group presentation and performance.

3. Cultural Awareness & Appreciation

- Respect shown towards different traditions.
- Ability to explain the role of music in celebrations.

4. Rhythm & Performance Skills

- Ability to perform simple rhythmic patterns.
- Coordination during group performance.

**Rubric
Assessment**

Criteria	Basic	Intermediate	Proficient
Understanding of Festivals	Identifies a few festivals with limited detail.	Identifies festivals with some explanation.	Clearly explains festivals and their origins.
Instrument Identification	Matches few instruments correctly.	Matches most instruments correctly.	Accurately matches all instruments with festivals.
Participation & Collaboration	Minimal contribution; needs guidance.	Participates with occasional support.	Fully engaged and supports group members actively.
Cultural Appreciation	Shows limited understanding of diversity.	Demonstrates general respect and awareness.	Shows strong appreciation and respect for cultural diversity.
Rhythm & Performance	Struggles to maintain rhythm.	Keeps rhythm with minor inconsistencies.	Maintains steady rhythm confidently.

WORKSHEET

Instructions:

- Join the dots by following the numbers in consecutive order to complete the pictures of the following musical instruments and then color them.
- Carefully cut out each instrument along the dotted lines.
- Paste each instrument into the correct festival box on the next page.

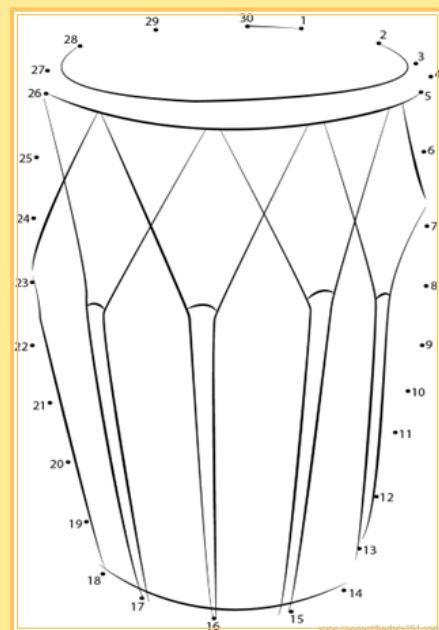
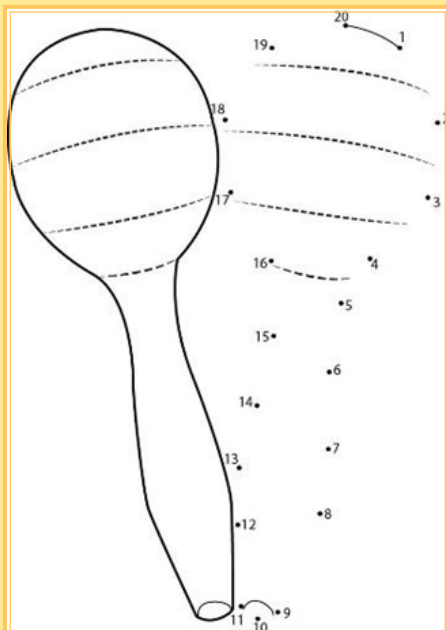
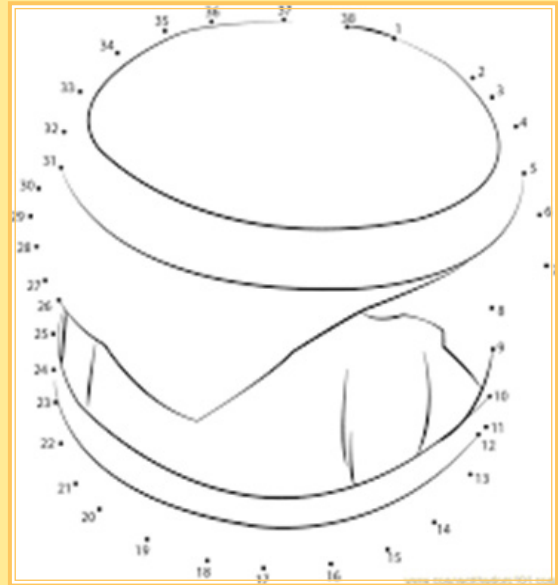
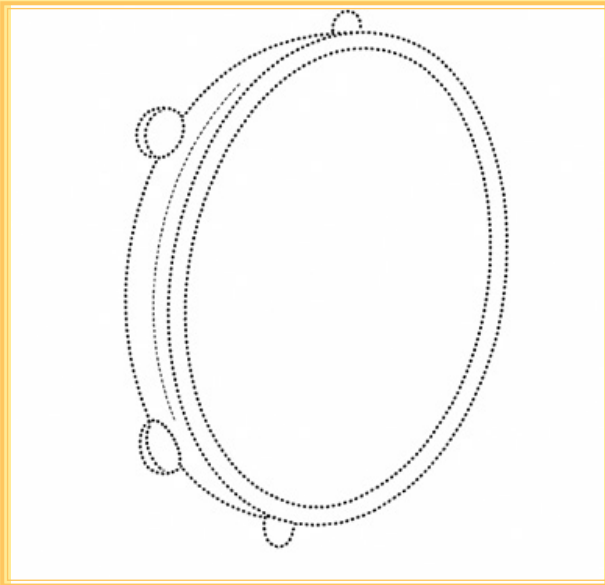



**Festivals in
Mauritius**

Easter

Holi

Chinese Spring Festival



**MOE
MAHATMA GANDHI INSTITUTE
2026**

